

Opening State

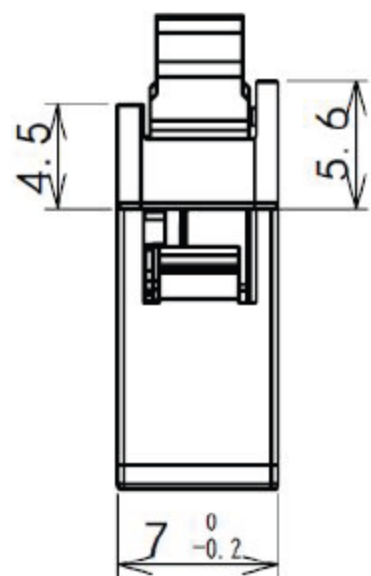

Closing State

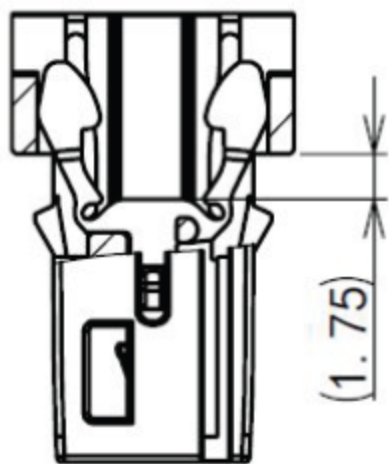
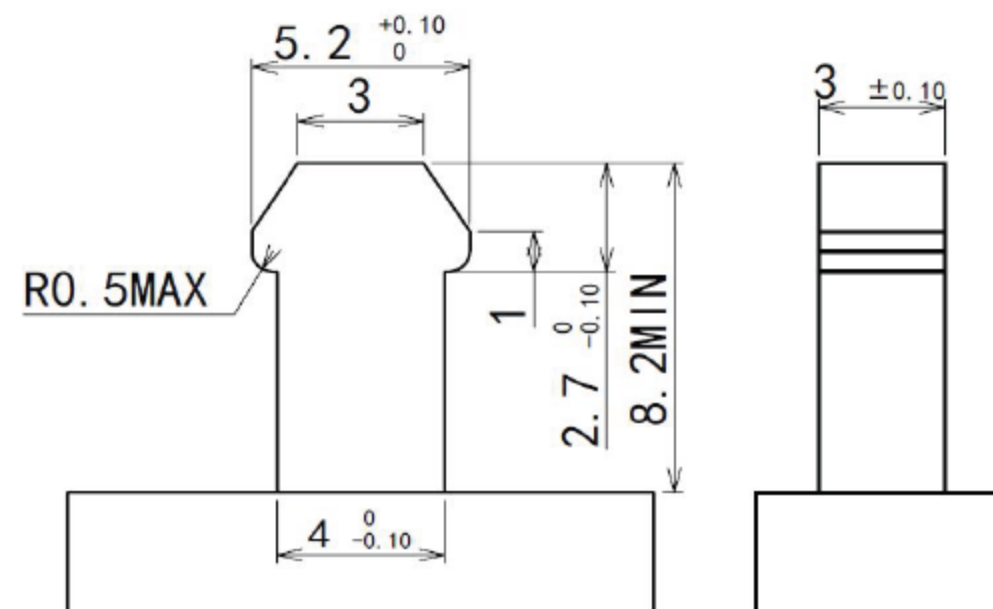

Max Pushing Distance

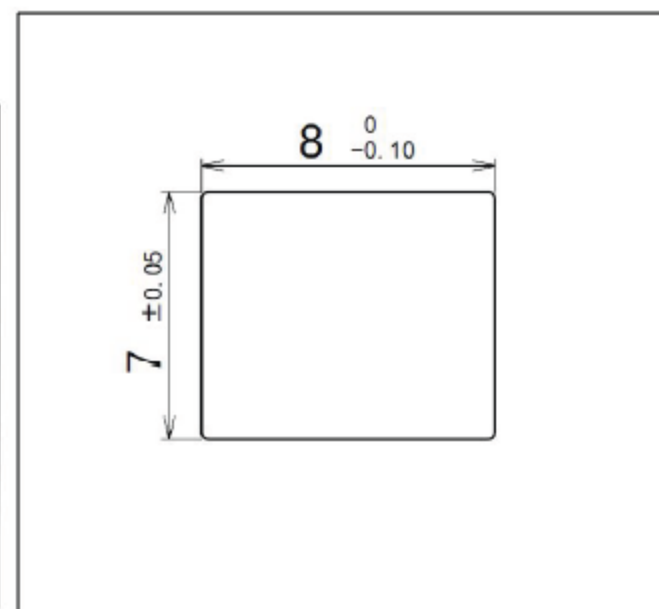
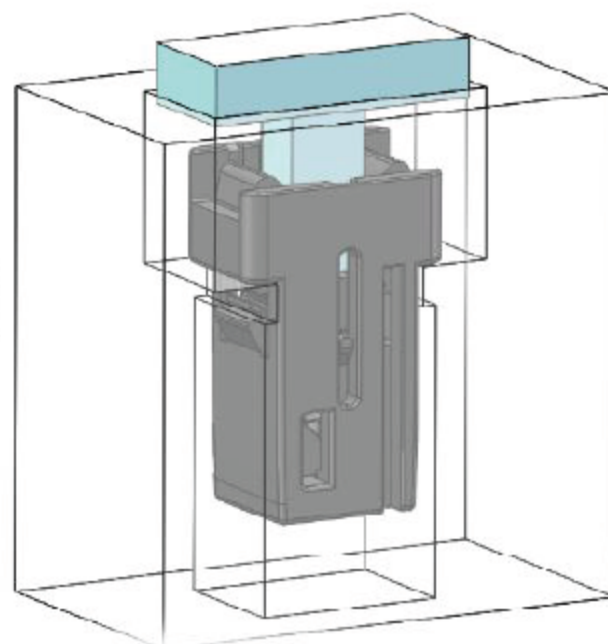
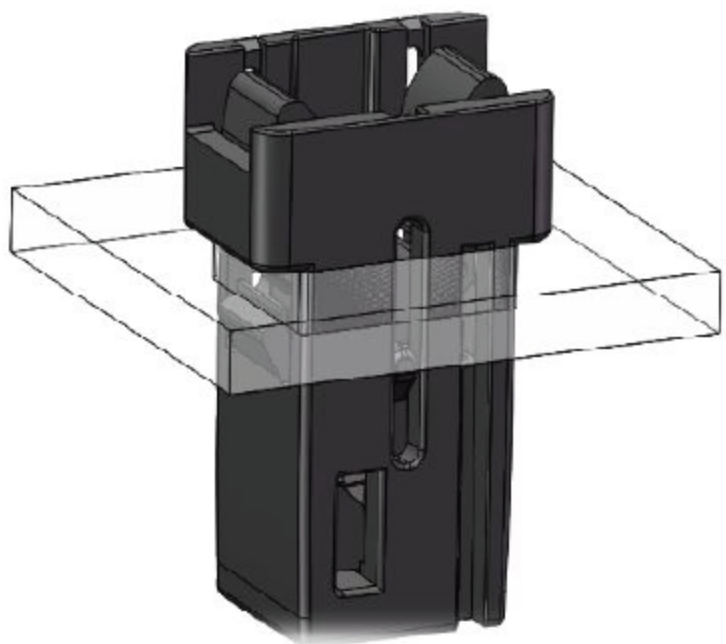

TITLE	DOOR LATCH SWITCH	DRAWN		TOLERANCE OTHERWISE UNLESS SPECIFIED	8					
PART NO.	Lock switch	CHECKED		UP TO 5	±0.2	6				
DRAW NO.	GD-PR-22	APPROVED		ABOVE 5 ~ 30	±0.3	5				
SCALE: 2:1	UNIT: mm	DATE:		ABOVE 30 ~ 50	±0.4	4				
				ABOVE 50	±0.5	3	SPRING	SUS	1 Ni PLATED	
				ANGLE	±3°	2	HOUSING	POM	1 BLACK	
						1	SLIDER	PA12	1 BLACK	
						NO.	PARTS	MATERIAL	QTY. FINISHING	
							DONG GUAN GAODI ELECTRONICS CO., LTD.			

東莞市高迪電子有限公司